

## Extra light-weight compactor

Designed for repair in confined areas. These plates are ideal for curbs, gutters, block paving around houses, tanks, forms, columns, footings, guard railings, drainage ditches, gas and sewer lines, and building works.

## FEATURES AND BENEFITS

- Special contoured surfaces, rounded edges and its low weight provide maximum performance and manoeuvrability.
- Completely enclosed belt protected by a light-weight belt guard for reduced wear and minimal service.
- Exciter bearing design requires minimal maintenance for improved productivity.
- Ergonomically designed foldable handles offer easier loading and unloading for operator during transport.
- Low HAV mechanism.
- Throttle cable mounted on the operator handle.



Ultra compact design

POWERED BY  
**HONDA**  
norm SAE J1349

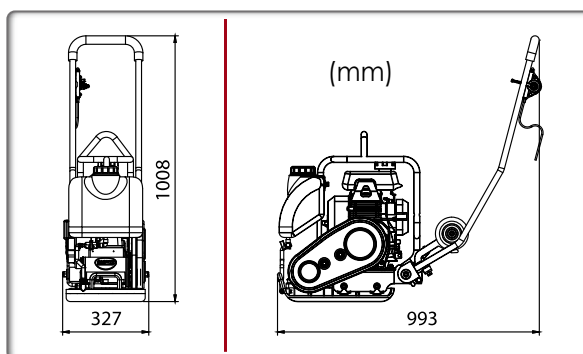

Code	LCC40W	LCC40R
Model	LCC40W	LCC40R
Operating mass (kg)	45	45
Centrifugal force (kN)	8,4	8,4
Plate width (mm)	320	320
Engine	Honda GXR120	Robin EH09
Power hp (kW)	3,5 (3)	3 (2,3)
Water tank (L)	6	6
Speed (m/min)	21	21
Amplitude (mm)	0,89	0,89
Frequency (Hz)	95	95
Sound pressure level dB (A)	89	89
Surface capacity (m <sup>2</sup> /h)	525	525
Vibrations* (m/s <sup>2</sup> )	3	3
* Minimum vibration levels measured to EN500-4		
Certified power SAE J 1349		

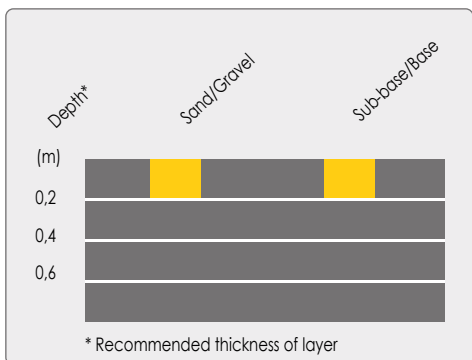

95 Hz



20°



8,4 kN



21 m/mn



Transport wheels included

COMPACTION

MOBILE EQUIPMENT

CONCRETE EQUIPMENT

SURFACING

CUTTING - GRINDING